

SS SYSTEM CATALOG

003	INTRODUCTION
012	CONTENTS
016	SS SYSTEM
062	USER MANUAL

CEO'S Message

Providing cutting edge technology and superior quality

Making products that dentists want to use,
trust, and are satisfied with :
This is our mission at **OSSEM IMPLANT**



**We are forever grateful
to all the dentists
who have given
unwavering support to
OSSTEM IMPLANT**

Thank you for using Osstem Implant. Osstem, Korea's first implant manufacturer, has secured world-class implant competitiveness through continuous R&D investment and quality innovation. It has grown to become Asia-Pacific No.1 and World No.5 Implant Company. In addition to dental implants and treatment tools, we are leading the development of products that are essential for dentists, including dental equipment, dental materials, and dental IT, and contribute to the development of the dental industry. The comprehensive catalog of the 2018-19 product series published here shows Osstem's technology-rich products. We have focused on catalog structure so that it is convenient to browse and order products. In particular, in the case of fixtures, abutments, and surgical tools, we introduced the diameter, length, and functions in detail.

GBR products are also easy to order by type, size and capacity. In addition, the product release date and time are displayed so that customers can understand when the existing product is released and what the newly released product is. We also introduced the CAD/CAM product in terms of preparing the digital dentistry, a major trend in the dentistry. In terms of design, we also implemented high-quality images of representative products by specification. By applying representative colors for each product system, it is easy to sort by category. We hope this will help you effectively find and purchase the products you need from the dental clinic of 2018-19. Osstem Implant will continue to develop products that the dentist can trust. We will work to create greater customer value. Thank you.

CEO of OSSTEM IMPLANT
Choi Kyu-ok (DDS.Ph.D)

Worldwide & History



1997

- 01 Established 'Osstem Co., Ltd.'
- 12 Released 'Doobunae' (health insurance claim application software program)

2001

- 01 Obtained CE-0434 certification
- 03 Established AIC training center

2006

- 03 Changed the company name to Osstem Implant Co., Ltd
- 04 Obtained GOST-R certification (russia)
- 12 Established 12 overseas branches (first round)

2008

- 01 Established osstem bone science research center
- 12 Selected as a managing organization for the national strategic technology development project

2010

- 03 Launched TSIII SA line
- 06 Launched TSIII HA line

2012

- 06 Launched TSIII CA line
- 07 Established osstem dental equipment research institute

2014

- 05 Selected as 'World Class 300'
- 05 Released 'HyFlex', an impression material
- 08 Released 'BeauTis' whitening material

2016

- 01 Established Vussen Co., Ltd.
- 03 Acquired Cardiotec Co., Ltd.
- 08 Acquired Hubit Co., Ltd.
- 11 Launched OneGuide system

2000

- 06 Released 'Hanaro' (dentistry management software)
- 10 Acquired sumin comprehensive dental materials

2002

- 01 Established Osstem Implant R&D center
- 08 Obtained FDA certification, launched USII line
- 10 Launched SSII line

2007

- 02 Listed on KOSDAQ and began trading publicly
- 06 Selected as No.1 products for the next generation and obtained TGA certification (australia)

2009

- 10 Obtained approval for medical device manufacturing and sale from the ministry of health, labor and welfare, japan

2011

- 06 Osstem Implant R&D center was selected as ATC (advanced technology center)
- 07 Selected as 'World Champ' business
- 12 Launched 'K2 unit chair', which was selected as a 'World Class Product'

2013

- 01 Launched osstem xenograft material 'A-Oss'
- 09 Launched 'K3 unit chair'
- 10 Selected as a 'Hidden Champion' company

2015

- 03 Established Osstem BioPharma Co., Ltd.
- 12 Awarded 'USD 50 Million Export Tower'

2017

- 12 2017 presidential commendation for job creation

2018

- 01 TS exceeded 10 million production

OSSTEM[®] Implant Design feature

OSSTEM IMPLANT has revolutionized implant dentistry in South Korea. With a focus on aggressive R&D, a commitment to education and a dedication to manufacturing the best products, Osstem Implant's ultimate goal is to become the global leader in implant dentistry.

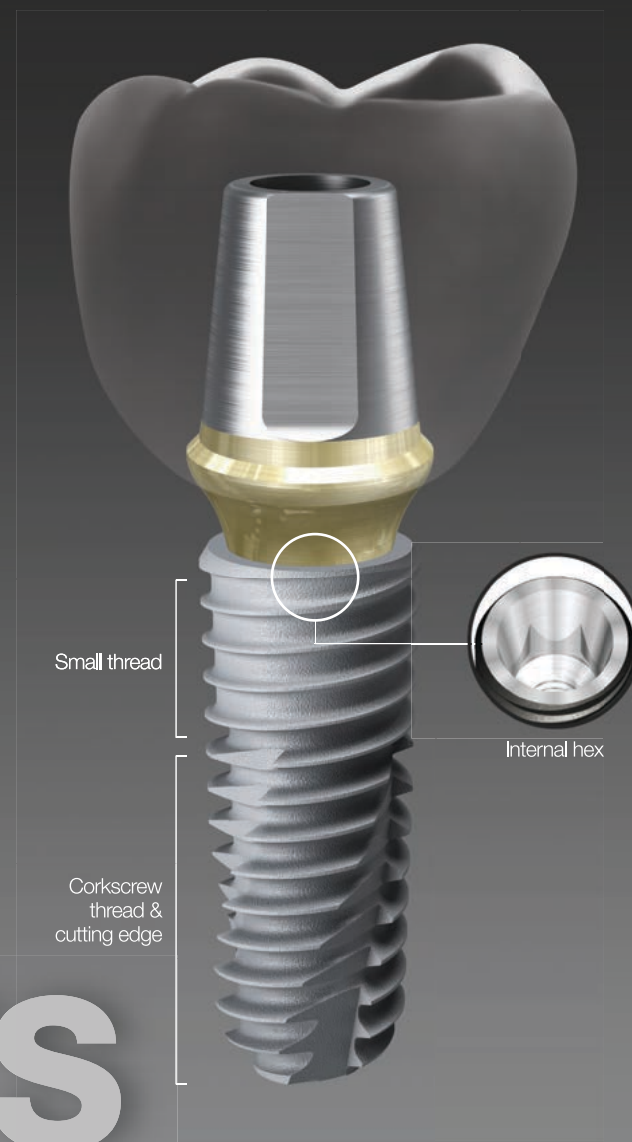

Submerged type implant with an internal hex and 11 tapered connection

- Internal connection type - Mini / Regular
- Excellent initial stability in soft bone due to smaller threads in the upper section
- Corkscrew thread with cutting edges
 - Strong self-threading effect for easy fixture path
 - Higher initial stability and consistent insertion torque
- Different body types to properly match the patient's bone quality and clinical condition
 - TSII (straight body) : easy to adjust depth
 - TSIII (1.5° tapered body) : excellent initial stability necessary for immediate loading, even in soft bone
 - TSIV (6° tapered body) : specifically designed for the maxillary sinus and soft bone, excellent initial stability
- Available surface types - SA / CA / HA / BA / SOI

Non-submerged type implant with an internal octa and 8 tapered connection

- Internal connection type - Regular / Wide
- Corkscrew thread with cutting edges
 - Strong self-threading effect for easy fixture path
 - Higher initial stability and consistent insertion torque
- Different body types to properly match the patient's bone quality and clinical condition
 - SSII (straight body) : easy to adjust the insertion depth
 - SSIII (1.5° tapered body) : excellent initial stability necessary for immediate loading, even in soft bone
- Available surface types - SA / CA / HA / BA

Submerged type implant with an external hex connection structure

- Internal connection type - Mini / Regular / Wide / Wide PS
- Corkscrew thread with cutting edges
 - Strong self-threading effect for easy fixture path
 - Higher initial stability and consistent insertion torque
- Different body types to properly match the patient's bone quality and clinical condition
 - USII (straight body) : easy to adjust the insertion depth
 - USIII (1.5° tapered body) : excellent initial stability necessary for immediate loading, even in soft bone
 - USIV (6° tapered body) : specifically designed for the maxillary sinus and soft bone, excellent initial stability
- Available surface types - SA / CA



Each implant system has its own unique color code

OSSTEM[®] Implant Surface feature

The key factor in providing implant treatment safely and efficiently is surface technology.

OSSTEM IMPLANT is proud of its cutting-edge surface technology.

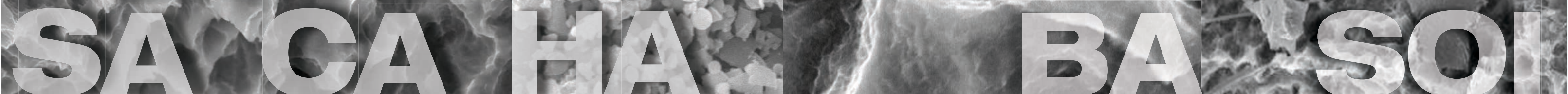

Acid Treated Optimized Surface

- Ra 2.5~3.0 μ m surface roughness (note : the upper 0.5mm part of the implant has Ra 0.5~0.6 μ m)
- Consistent surface micro pits between 1 to 3 μ m
- Surface area is increased by 46 percent compared to RBM treated implants

In-vitro & In-vivo Bone Response

- 20% improvement in osteoblast separation and ossification compared to RBM
- Initial bone reaction performance in animal model (mini-pig)
- 48% improvement in initial stability (RT, 4 weeks) compared to RBM
- 20% improvement in ossification (BIC, 4 weeks) compared to RBM

Super-hydrophilic SA surface suspended in a calcium solution

- Same SA surface morphology
- Optimizing surface reaction by suspension in a calcium (CaCl₂) solution
- Increased new bone formation area due to the excellent blood wettability
- Bone response improved in early osseointegration stage compared to standard SA surface

In-vitro & In-vivo Bone Response

- Protein and cellular adhesion tripled compared to SA surfaces
- Initial cellular differentiation by 19 percent compared to SA surfaces (7 days)
- Initial stability increased by 34 percent compared to SA surfaces (RT at 4 weeks)
- Ossification rate Increased by 26 percent compared to SA surfaces (BIC at 4 weeks)

Premium high-crystalline HA-coated surface

- 30 to 60 μ m thick high-crystalline HA coating
- HA coated onto a RBM surface (Ra 3.0 to 3.5 μ m)
- High HA crystalline over 98 percent
- Solved the problem with low-crystalline HA resorption

In-vitro & In-vivo Bone Response

- Excellent biocompatibility in HA that is similar to bone
- Initial ossification by osteoblasts doubled compared to SA surfaces (5 days)
- 40% improvement in initial stability (RT, 4 weeks) in animal models compared to SA
- Suitable for poor bone quality, tooth extraction sites or immediate implant insertion

Premium low crystalline nano-HA coated SA surface

- SA surface (Ra 2.5 to 3.0 μ m) coated with HA
- 10nm ultra-thin HA coating
- Dual function between titanium and HA
- HA is naturally resorbed during ossification

In-vitro & In-vivo Bone Response

- Advantages of both SA and HA surfaces
- SA's ability to maintain an optimal surface
- HA's ability to form high quality initial bone, even in a poor bone quality
- 40% improvement in ossification (BIC) compared to SA
- It is applicable to all types of bone quality

Next-generation surface coated with special material (K material)

- Activation of blood clot formation
- Avoid carbon adsorption in air
- Coating of K material on SA surface (Ra 2.0~3.0 μ m)
- Superior blood wettability with super hydrophilic surface.

In-vitro & In-vivo Bone Response

- Protein and cellular adhesion 130 times increase compared to SA surface
- Initial stability increased by 57 percent compared to SA surfaces (RT at 4 weeks)
- Surface with the shortest duration of surgery

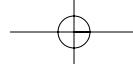

OSSTEM[®]
IMPLANT

FIXTURE

- O16 SSII SA Fixture
- O18 SSIII SA Fixture
- O20 Simple Mount
- O20 Cover Screw
- O21 Closing Screw
- O22 Healing Abutment

COMPONENTS

- O24 PROSTHETIC FLOW DIAGRAM 1
- O25 Solid Abutment
- O29 Excellent Solid Abutment
- O34 PROSTHETIC FLOW DIAGRAM 2
- O35 ComOcta Abutment
- O36 ComOcta Plus Abutment
- O38 ComOcta Milling Abutment
- O39 ComOcta Gold Abutment
- O40 ComOcta NP-Cast Abutment
- O41 ComOcta Temporary Abutment
- O42 OneFit Abutment
- O43 Pre-Milled Abutment
- O44 ComOcta Angled Abutment
- O48 PROSTHETIC FLOW DIAGRAM 3
- O49 Octa Abutment
- O54 PROSTHETIC FLOW DIAGRAM 4
- O55 O-ring Abutment
- O57 Locator[®] Abutment

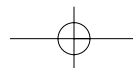

SSII SA Fixture

- Non-submerged type implant with an internal octa and 8° tapered connection
- Optimized screw thread design with the ideal SA surface
- Straight body design allows easy insertion depth adjustments
- Excellent initial stability in soft bone due to small threads in the upper section
- Corkscrew threading with excellent self-threading effect
- Recommended insertion torque : ≤40 Ncm
- ※ Fixtures with a diameter of 4.5mm or more are recommended for the posterior area

NoMount fixture order code

: fixture product code (ex : SS2R4011S18)

Pre-Mounted fixture (fixture + simple mount + cover screw) order code

: **A** + fixture product code (ex : ASS2R4011S18)

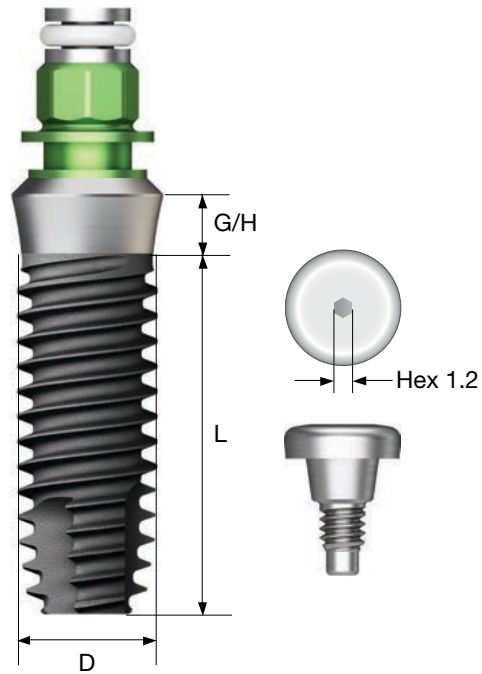

D Ø5.0
P Ø6.0
W

G/H \ L	6	7	8.5	10	11.5	13
Short						
2.0	SS2W5006S20	SS2W5007S20	SS2W5008S20	SS2W5010S20	SS2W5011S20	SS2W5013S20

016

SS SYSTEM

D Ø4.0
P Ø4.8
R

G/H \ L	7	8.5	10	11.5	13
1.8	SS2R4007S18	SS2R4008S18	SS2R4010S18	SS2R4011S18	SS2R4013S18
2.8		SS2R4008S28	SS2R4010S28	SS2R4011S28	SS2R4013S28

D Ø4.5
P Ø4.8
R

G/H \ L	7	8.5	10	11.5	13
1.8	SS2R4507S18	SS2R4508S18	SS2R4510S18	SS2R4511S18	SS2R4513S18
2.8		SS2R4508S28	SS2R4510S28	SS2R4511S28	SS2R4513S28

D Ø4.5
P Ø6.0
W

G/H \ L	7	8.5	10	11.5	13
2.0	SS2W4507S20	SS2W4508S20	SS2W4510S20	SS2W4511S20	SS2W4513S20

017

SS SYSTEM

Nominal and actual diameters may slightly differ

Caution For a short implant, a sufficient healing period is strongly recommended. A short implant should be splinted with another implant when considering prosthetic options.

SSIII SA Fixture

- Non-submerged type implant with an internal octa and 8° tapered connection
- Optimized screw thread design with the ideal SA surface
- Tapered body design with high initial stability
- Excellent initial stability in soft bone due to the small thread on the upper part
- Corkscrew threading with excellent self-threading effect
- Excellent initial stability necessary for immediate loading, even in soft bone

Ultra-wide

- Ideal for an extracted tooth site in the posterior area, for immediate placement, or for replacing a failed implant
- Apex is specifically design for excellent initial stability in an extracted tooth site
- Recommended insertion torque : ≤ 40 Ncm
- ※ Fixtures with a diameter of 4.5mm or more are recommended for the posterior area

NoMount fixture order code

: fixture product code (ex : SS3R4011S18)

Pre-Mounted fixture (fixture + simple mount + cover screw) order code

: A + fixture product code (ex : ASS3R4011S18)

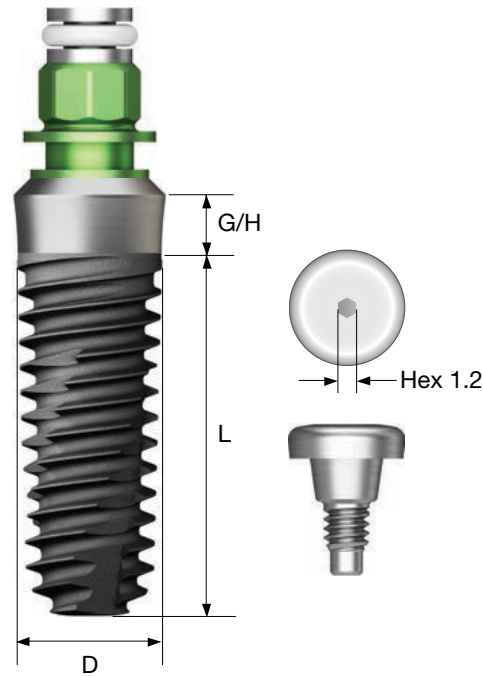

D Ø4.5
P Ø6.0



G/H \ L	7	8.5	10	11.5	13
2.0					
	SS3W4507S20	SS3W4508S20	SS3W4510S20	SS3W4511S20	SS3W4513S20

D Ø5.0
P Ø6.0



G/H \ L	6	7	8.5	10	11.5	13
2.0						
	SS3W5006S20	SS3W5007S20	SS3W5008S20	SS3W5010S20	SS3W5011S20	SS3W5013S20

Ultra-wide

D Ø6.0
P Ø6.0



G/H \ L	6	7	8.5	10	11.5	13
2.0						
	SS3WB6006S20	SS3WB6007S20	SS3WB6008S20	SS3WB6010S20	SS3WB6011S20	SS3WB6013S20

D Ø7.0
P Ø6.0



G/H \ L	6	7	8.5	10	11.5	13
2.0						
	SS3WB7006S20	SS3WB7007S20	SS3WB7008S20	SS3WB7010S20	SS3WB7011S20	SS3WB7013S20

Nominal and actual diameters may slightly differ

Caution For a short implant, a sufficient healing period is strongly recommended. A short implant should be splinted with another implant when considering prosthetic options.

D Ø3.5
P Ø4.8



G/H \ L	8.5	10	11.5	13
1.8				
2.8	SS3R3508S18	SS3R3510S18	SS3R3511S18	SS3R3513S18
	SS3R3508S28	SS3R3510S28	SS3R3511S28	SS3R3513S28

D Ø4.0
P Ø4.8



G/H \ L	7	8.5	10	11.5	13
1.8					
2.8	SS3R4007S18	SS3R4008S18	SS3R4010S18	SS3R4011S18	SS3R4013S18
	SS3R4007S28	SS3R4008S28	SS3R4010S28	SS3R4011S28	SS3R4013S28

D Ø4.5
P Ø4.8



G/H \ L	7	8.5	10	11.5	13
1.8					
2.8	SS3R4507S18	SS3R4508S18	SS3R4510S18	SS3R4511S18	SS3R4513S18
	SS3R4507S28	SS3R4508S28	SS3R4510S28	SS3R4511S28	SS3R4513S28

Mount & Screw

Simple Mount

- Select appropriate mount according to the fixture platform
- Use a 1.2 hex driver (fasten manually)
- ※ Disposable; do not re-use
- P = Platform

R Regular
W Wide

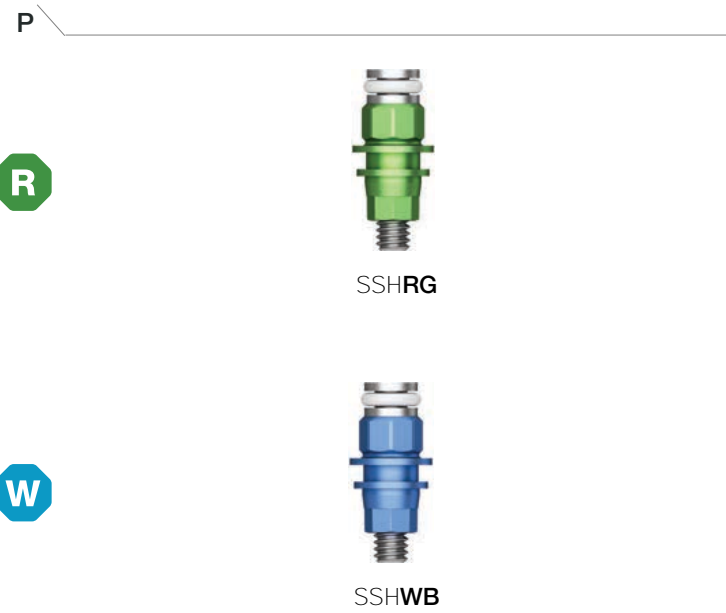

Closing Screw

- Used when the soft tissue of the suture part is insufficient
- Use of 1.2 hex driver with hand force
- P = Platform

R Regular
W Wide



Cover Screw

- Select appropriate mount according to the fixture platform
- Use a 1.2 hex driver (fasten manually)
- P = Platform

R Regular
W Wide

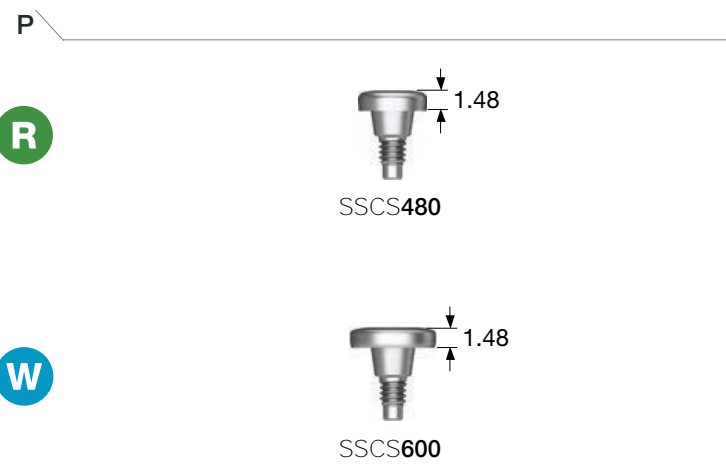

Healing Abutment

- Select appropriate mount according to the fixture platform
- Use a 1.2 hex driver (fasten manually)
- P = Platform

R Regular
W Wide



OSSTEM[®]
 IMPLANT

022

SS SYSTEM

P \ H	2.0	3.0	4.0	5.0
Ø 4.8	SSH482	SSH483	SSH484	SSH485

P \ H	2.0	3.0	4.0	5.0
Ø 6.0	-	SSH603	SSH604	SSH605

023

SS SYSTEM

PROSTHETIC FLOW DIAGRAM 1
Solid / Excellent Solid
 Abutment Level Impression

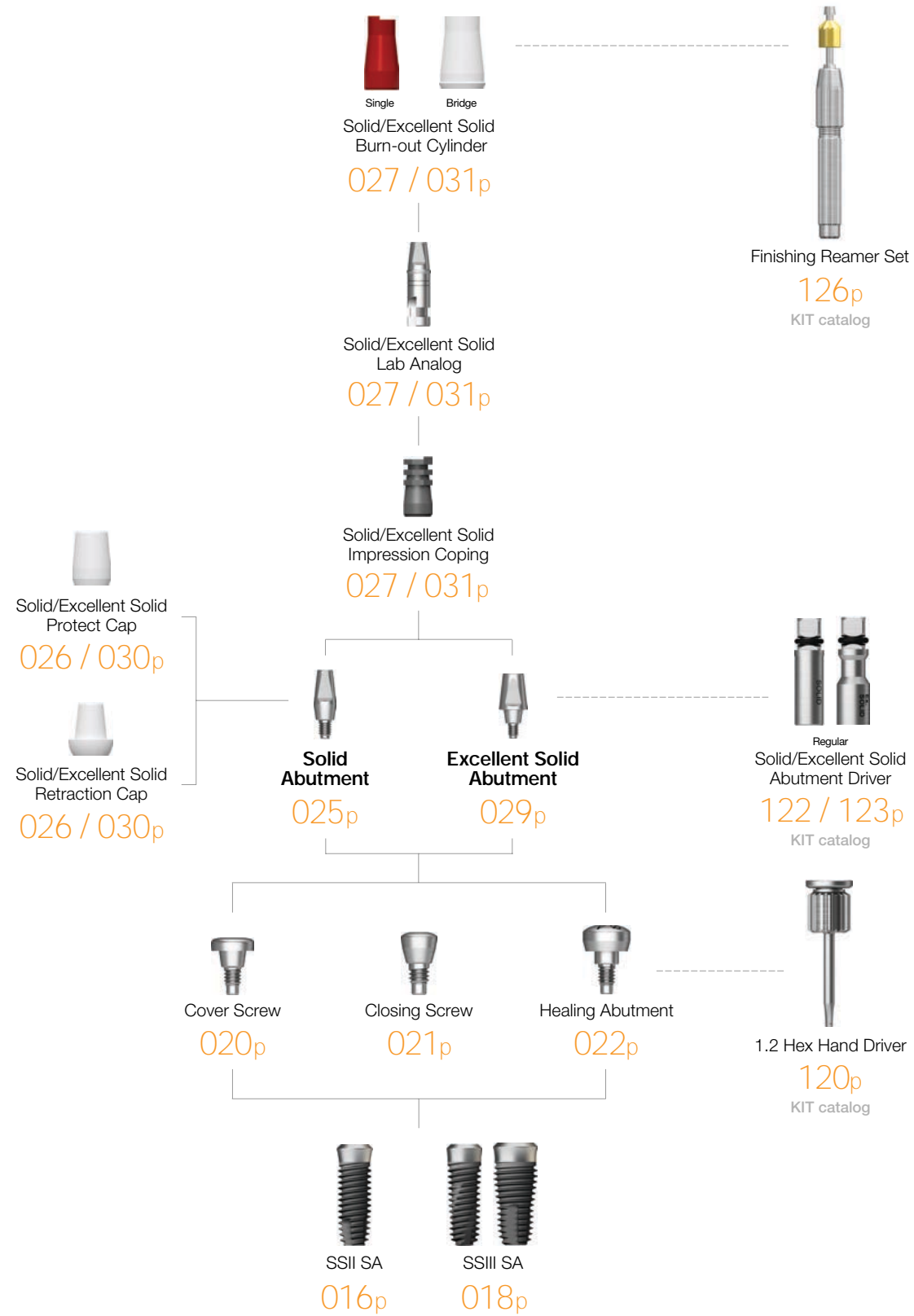

Solid Abutment



- Cement-retained prosthesis
- Abutment level impression
- $\varnothing 4.8$: connect using a solid abutment driver (code : SDSL/SDSS)
- $\varnothing 6.0$: connect using a 1.2 hex driver or solid abutment driver
- Recommended tightening torque : 30Ncm
- Packing unit : abutment + protect cap

Abutment + protect cap order code
 : product code + P (ex : SSS485P)

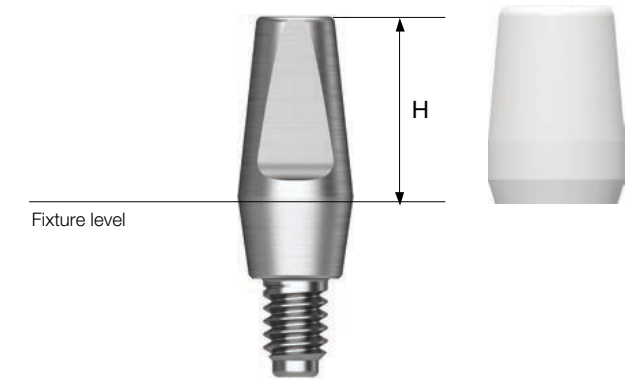

D $\varnothing 4.8$



D $\varnothing 6.0$



024

SS SYSTEM

025

SS SYSTEM

Solid Abutment Components

Solid Protect Cap

- Protects the solid abutment and minimizes patient irritation
- Can be used as the base for a provisional crown

R Regular
W Wide

D \ H	4.0	5.5	7.0
Ø 4.8	SSC484	SSC485	SSC487
Ø 6.0	SSC604	SSC605	SSC607

Solid Impression Coping

- Components for solid abutment impression
- Possibility of precise prosthesis using lab analog
- Color coded by abutment height

R Regular
W Wide

D \ H	4.0	5.5	7.0
Ø 4.8	SSIC484	SSIC485	SSIC487
Ø 6.0	SSIC604	SSIC605	SSIC607

Solid Retraction Cap

- Possible to get clear margin by pushing out gingiva around margin in solid abutment direct impressions
- Used for accurate margin reproduction when taking a direct impression
- Can be used as the base for a provisional crown

R Regular
W Wide

D \ H	4.0	5.5	7.0
Ø 4.8	SSSRC484	SSSRC485	SSSRC487
Ø 6.0	SSSRC604	SSSRC605	SSSRC607

Solid Lab Analog

- Components that replace resin caps before wax up using solid abutments
- Used in the same color as solid impression coping

R Regular
W Wide

D \ H	4.0	5.5	7.0
Ø 4.8	SSSA484	SSSA485	SSSA487
Ø 6.0	SSSA604	SSSA605	SSSA607

Solid Burn-out Cylinder

- Solid abutment components that reproduce them on the model after impression taking
- Sophisticated prosthesis can be produced inside
- After casting, remove the lower part of the margin holding part

R Regular
W Wide

D \ H	Single	Bridge
Ø 4.8	SSSP480S	SSSP480B
Ø 6.0	SSSP600S	SSSP600B

Solid Abutment Components

Solid Impression Cap

- An impression cap used when the solid abutment is trimmed
- Used with a solid shoulder analog and analog pin

- R** Regular
- W** Wide

Ø 4.8
Ø 6.0



Solid Shoulder Analog

- Impression product used when removing solid abutment
- Reproducing the platform part of the fixture in the work model
- Used with solid impression cap and shoulder analog pin

- R** Regular
- W** Wide

Ø 4.8
Ø 6.0



Solid Shoulder Analog Pin

- An impression coping component used when the solid abutment is trimmed
- Reinforces the narrow part of the abutment
- Used with a solid shoulder analog and impression cap

- R** Regular
- W** Wide

Ø 4.8
Ø 6.0



Excellent Solid Abutment



- Cement-retained prosthesis
- Ideal for molar cases due to its larger volume (compared to the solid abutment), trim as needed
- Abutment level impression
- Ø 4.8 : connect using a 1.2 hex driver or an excellent solid abutment driver (code : ESDSS/ESDSL)
- Ø 6.0 : connect using a 1.2 hex driver or an excellent solid abutment driver (code : ESD60S)
- Recommended tightening torque: 30Ncm
- Packing unit : abutment + protect cap

Abutment + protect cap order code
: product code + P (ex : SSE485P)

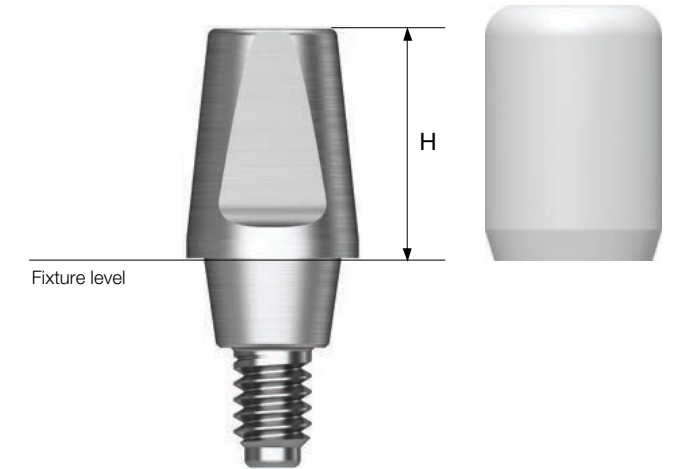

D Ø 4.8
R



D Ø 6.0
W









Excellent Solid Abutment Components

Excellent Solid Protect Cap

- Protects the solid abutment and minimizes patient irritation
- Can be used as the base for a provisional crown





R Regular
W Wide

D \ H	4.0	5.5	7.0
Ø 4.8	 SSEC484	 SSEC485	 SSEC487
Ø 6.0	 SSEC604	 SSEC605	 SSEC607

Excellent Solid Impression Coping

- Impression components for Excellent solid abutment
- Possibility of precise prosthesis using lab analog
- Color coded by abutment height



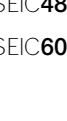
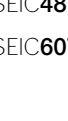



R Regular
W Wide

D \ H	4.0	5.5	7.0
Ø 4.8	 SSEIC484	 SSEIC485	 SSEIC487
Ø 6.0	 SSEIC604	 SSEIC605	 SSEIC607

Excellent Solid Retraction Cap

- Used for accurate margin reproduction when taking a direct impression
- Possible to get clear margin in excellent solid abutment direct impressions
- Can be used as the base for a provisional crown

R Regular
W Wide

D \ H	4.0	5.5	7.0
Ø 4.8	 SSERC484	 SSERC485	 SSERC487
Ø 6.0	 SSERC604	 SSERC605	 SSERC607

Excellent Solid Lab Analog

- Components that replace resin caps before wax up using excellent solid abutments
- Connect to the appropriate color coded with solid impression coping

R Regular
W Wide

D \ H	4.0	5.5	7.0
Ø 4.8	 SSEA484	 SSEA485	 SSEA487
Ø 6.0	 SSEA604	 SSEA605	 SSEA607

Excellent Solid Burn-out Cylinder

- Excellent solid abutment components that reproduce this on the model after impression taking
- Sophisticated prosthesis can be produced inside
- After casting, remove the lower part of the margin holding part

R Regular
W Wide

D \ H	Single	Bridge
Ø 4.8	 SSEP480S	 SSEP480B
Ø 6.0	 SSEP600S	 SSEP600B

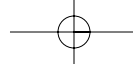

Excellent Solid Abutment Components

Excellent Solid Impression Cap

- An impression cap used when the solid abutment is trimmed
- Used with an excellent solid shoulder analog and an analog pin

R Regular

W Wide

D

Ø 4.8

Ø 6.0



SSEIP480

SSEIP600

Excellent Solid Shoulder Analog

- Impression product used when removing excellent solid abutment
- Reproducing the platform part of the fixture in the work model
- Used with excellent solid impression cap and shoulder analog pin

R Regular

W Wide

D

Ø 4.8

Ø 6.0



SSSLA480

SSSLA600

OSSTEM[®]
IMPLANT

Excellent Solid Shoulder Analog Pin

- An impression coping component used when the solid abutment is trimmed
- Reinforces the narrow part of the abutment
- Used with an excellent solid shoulder analog and an impression cap

R Regular

W Wide

D

Ø 4.8

Ø 6.0



SSSAP480

032

SS SYSTEM

033

SS SYSTEM

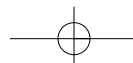

PROSTHETIC FLOW DIAGRAM 2
ComOcta / OneFit
 Fixture Level Impression

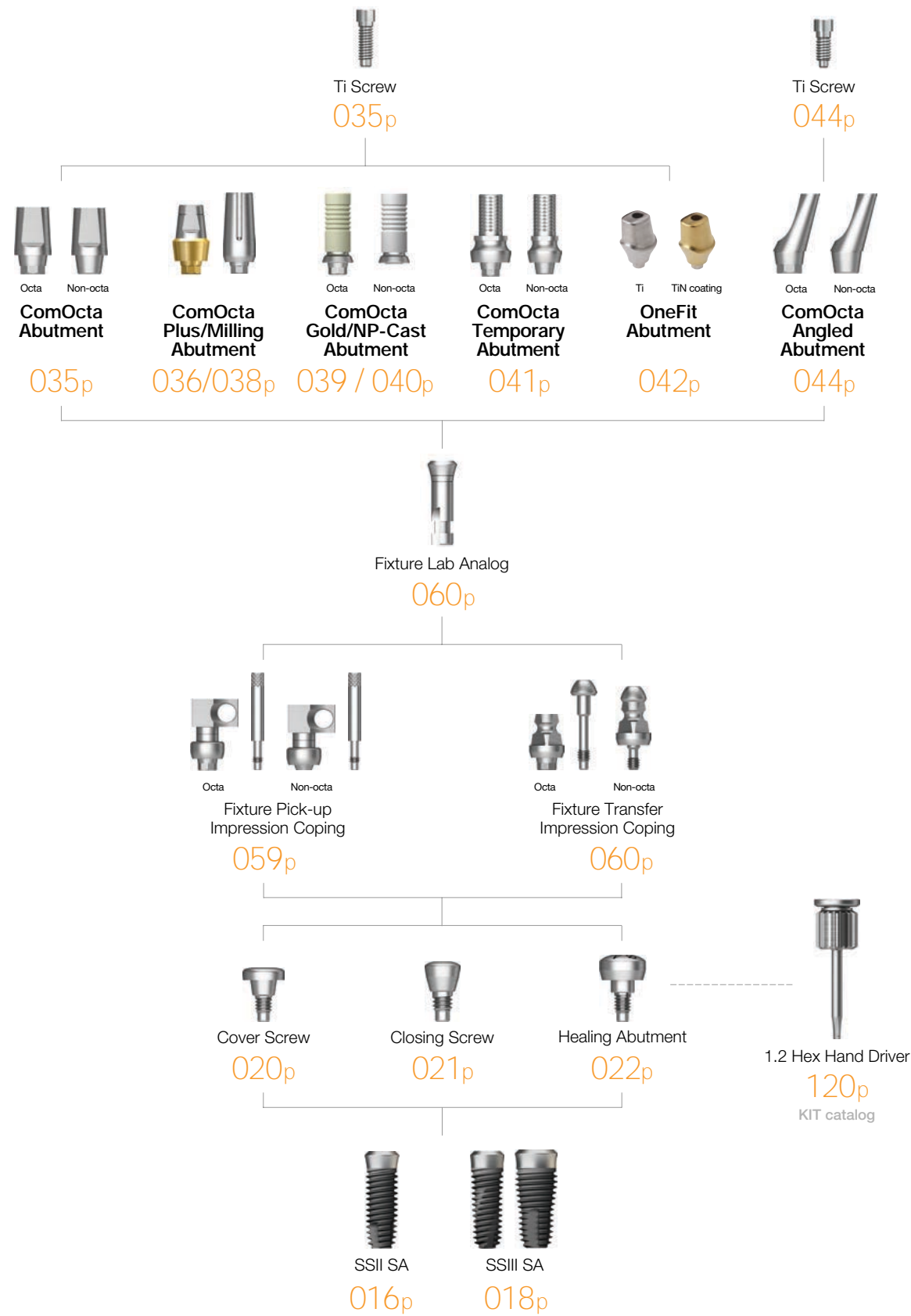

ComOcta Abutment



- Cement/combination-retained prosthesis
- Fixture level impression
- Able to take abutment level impression using a retraction cap
- Use a 1.2 hex driver
- Recommended tightening torque : 30Ncm
- Packing unit : abutment + Ti screw

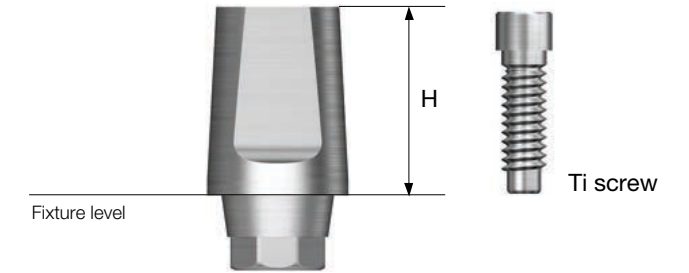

Abutment + Ti screw order code
 : product code + TH (ex : SSCA485TH)

D Ø4.8



Ti screw : ASR200

H Type	4.0	5.5	7.0	4.0	5.5	7.0
	Octa			Non-Octa		
	SSCA484	SSCA485	SSCA487	SSCA484N	SSCA485N	SSCA487N

D Ø6.0



Ti screw : ASR200

H Type	4.0	5.5	7.0	4.0	5.5	7.0
	Octa			Non-Octa		
	SSCA604	SSCA605	SSCA607	SSCA604N	SSCA605N	SSCA607N

034

SS SYSTEM

035

SS SYSTEM

ComOcta Plus Abutment



- Cement / combination abutment for prosthesis manufacturing
- Used when the gingiva is thick or the fixture is deeply implanted
- Abutment - fixture interlock is 45° platform contact
- Fixture level impression
- Use of 1.2 hex driver
- Recommended torque of tightening screw : 30Ncm
- Packing unit : abutment + Ti screw

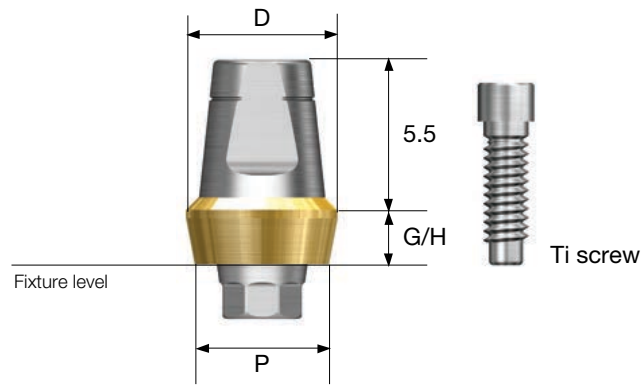

Abutment + Ti screw order code
: product code + TH (ex : SSCAP4826CTH)

P Ø6.0



Ti screw
: ASR200

	G/H D	1.0 Ø6.5	2.0 Ø6.5	3.0 Ø6.5	4.0 Ø6.5
Octa					
Non-Octa		SSCAP6016CN	SSCAP6026CN	SSCAP6036CN	SSCAP6046CN

	G/H D	2.0 Ø6.8	3.0 Ø7.2	4.0 Ø7.6
Octa				
Non-Octa		SSCAP6026EN	SSCAP6036EN	SSCAP6046EN

036

P Ø4.8



Ti screw
: ASR200

	G/H D	1.0 Ø5.5	2.0 Ø5.5	3.0 Ø5.5	4.0 Ø5.5
Octa					
Non-Octa		SSCAP4816CN	SSCAP4826CN	SSCAP4836CN	SSCAP4846CN

	G/H D	2.0 Ø6.0	3.0 Ø6.5	4.0 Ø7.0
Octa				
Non-Octa		SSCAP4826EN	SSCAP4836EN	SSCAP4846EN

037

SS SYSTEM

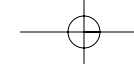

ComOcta Milling Abutment

- Cement/combination-retained prosthesis
- Used when the abutment's margin shape needs corrections
- Abutment fastens to the platform at a 45° angle
- Fixture level impression
- Use a 1.2 hex driver
- Recommended tightening torque : 30Ncm
- Packing unit : abutment + Ti screw

Abutment + Ti screw order code
: product code + TH (ex : SSCMA4830TH)

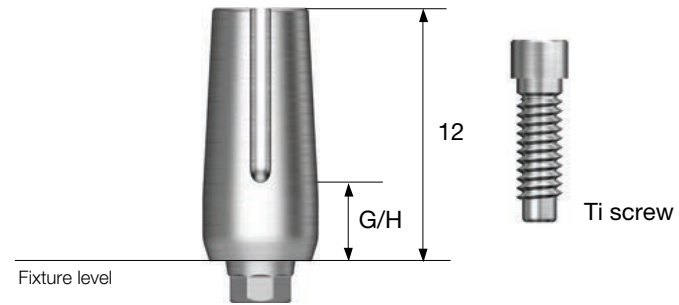

ComOcta Gold Abutment



- Cement/combination/screw-retained prosthesis
- Customized prosthesis cast with gold alloy
- Abutment fastens to the platform at a 45° angle
- Abutment melting point : 1400~1450°C
- Fixture level impression
- Use a 1.2 hex driver
- Recommended tightening torque : 30Ncm
- Packing unit : abutment + Ti screw

Abutment + Ti screw order code
: product code + TH (ex : COG480STH)

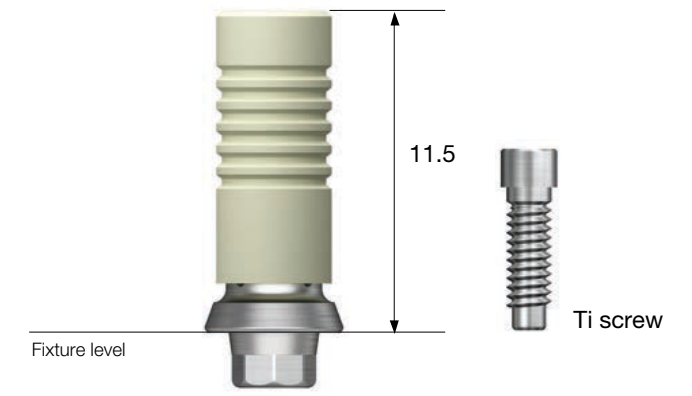

038

SS SYSTEM

D Ø4.8 / G/H **3.0**

R

Ti screw : ASR200



SSCMA4830

D Ø6.0 / G/H **3.0**

W

Ti screw : ASR200



SSCMA6030

P Ø4.8 / Type **Octa** **Non-Octa**

R

Ti screw : ASR200



COG480S



COG480B

P Ø6.0 / Type **Octa** **Non-Octa**

W

Ti screw : ASR200



COG600S



COG600B

039

SS SYSTEM

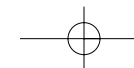

ComOcta NP-Cast Abutment

- Cement/combination/screw-retained prosthesis
- Customized prosthesis cast with non-precious alloys
- Abutment fastens to the platform at a 45° angle
- Abutment melting point : 1400~1450°C
- Fixture level impression
- Use a 1.2 hex driver
- Recommended tightening torque : 30Ncm
- Packing unit : abutment + Ti screw

Abutment + Ti screw order code
: product code + TH (ex : CON480STH)

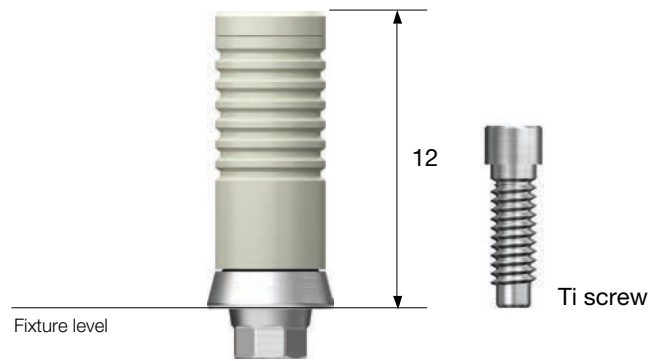

ComOcta Temporary Abutment

- Cement/screw-retained prosthesis
- A trim able provisional prosthesis (made of Ti Gr-3)
- Fixture level impression
- Use a 1.2 hex driver
- Recommended tightening torque : 20Ncm
- Packing unit : abutment + Ti screw

Abutment + Ti screw order code
: product code + TH (ex : SSTA0480TH)

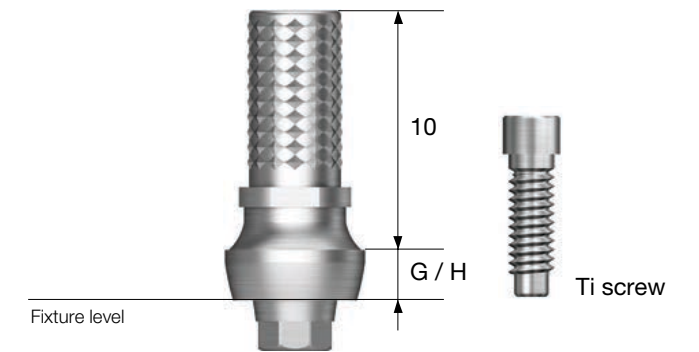

040

SS SYSTEM

D Ø4.8



Ti screw : ASR200

Type **Octa** **Non-Octa**



CON480S



CON480B

D Ø6.0



Ti screw : ASR200

Type **Octa** **Non-Octa**



CON600S



CON600B

D Ø4.8



Ti screw : ASR200

G/H Type **0** **2.0** / **0** **2.0**
Octa Non-Octa



SSTA0480



SSTA0482



SSTAN480



SSTAN482

D Ø6.0



Ti screw : ASR200

G/H Type **0** **2.0** / **0** **2.0**
Octa Non-Octa



SSTA0600



SSTA0602



SSTAN600



SSTAN602

041

SS SYSTEM

OneFit Abutment

- Cement/combination-retained prosthesis
- CAD/CAM designed and milled customized abutments
- Fixture level impression
- Possibility of abutment level impression when using Scan healing abutment
- Lead time (by working days)
 - Titanium : 5 days
 - Titanium + gold color : 7 days
- Use a 1.2 hex driver
- Recommended tightening torque : 30Ncm
- Packing unit : abutment + Ti screw



Pre-Milled Abutment

- Manufacturing custom abutment with dental milling equipment
- Excellent tightening precision compared to unauthentic
- Packing unit : abutment + Ti screw

Pre-milled abutment + screw order code
: product code + TH (ex : SSPM10AGRTH)

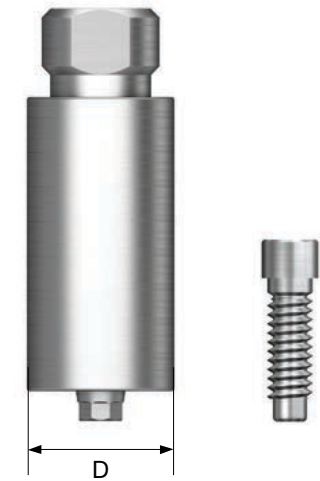

Scan Body

- Scan body for manufacturing a titanium SmartFit abutment
- Use a 1.2 hex driver (fastened manually)
- Packing unit : scan body + Ti screw

Scan body + screw order code
: product code + TH (ex : SSSBMTH)

- R** Regular
- W** Wide



Green color screw
: USSBRS



SSSBR



Green color screw
: USSBRS



SSSBW

Equipment	Implant	D	Specifications		Code
DooWon ARUM	Osstem SS	Ø10	Regular	Octa	SSPM10AGRTH
			Regular	Non-octa	SSPM10AGRNTH
			Wide	Octa	SSPM10AGWTH
			Wide	Non-octa	SSPM10AGWNTH

ComOcta Angled Abutment



- Cement/combination-retained prosthesis
- Angle compensation between 15°/20°
- Use dedicated abutment screw
- Fixture level impression
- Fastened using a 1.2 hex driver
- Recommended tightening torque: 30Ncm
- Packing unit : abutment + Ti screw(only angled)

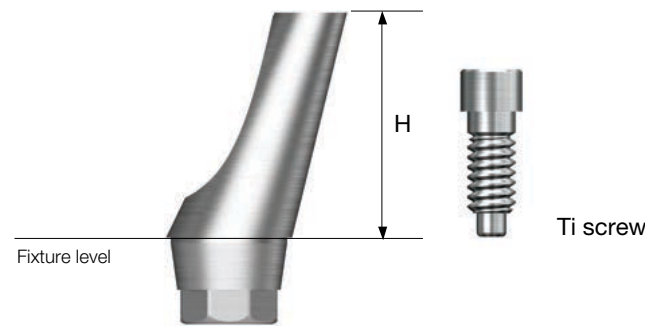

Abutment + Ti screw order code
: product code + TH (ex : SSA4815TH)

044

SS SYSTEM

D Ø4.8



Ti screw : ASS200

Angle Type	15°	20°	15°	20°
	Octa		Non-Octa	
Image				
Code	SSA4815	SSA4820	SSA4815N	SSA4820N

D Ø6.0



Ti screw : ASS200

Angle Type	15°	20°	15°	20°
	Octa		Non-Octa	
Image				
Code	SSA6015	SSA6020	SSA6015N	SSA6020N

ComOcta Abutment Components

ComOcta Retraction Cap

- Used for accurate margin reproduction when taking a direct impression
- Can be used as the base for a provisional crown

- R** Regular
- W** Wide

D \ H	4.0	5.5	7.0
Image			
Code	SSCRC484	SSCRC485	SSCRC487
Ø	Ø 4.8	Ø 5.5	Ø 7.0
Code	SSCRC604	SSCRC605	SSCRC607

Fixture Pick-up Impression Coping

- Components for fixture level impression taking
- For open tray impressions
- Unique design that is fixed position in the impression material
- Use a 1.2 hex driver (torque manually)
- Packing unit : impression coping body + guide pin(*)

- R** Regular (Green)
- W** Wide (Blue)

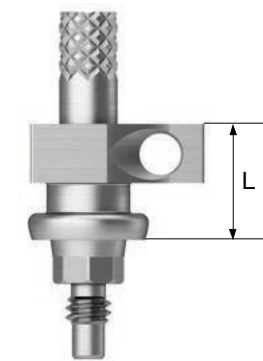

P \ L	5		10		Guide Pin		
Type	Octa	Non-Octa	Octa	Non-Octa	10	15	17
Image							
Code	SSICAS480	SSICAS480N	SSICA480	SSICA480N	CSR100*(L5)	CSR150*(L10)	CSR170
Code	SSICAS600	SSICAS600N	SSICA600	SSICA600N			

045

SS SYSTEM

ComOcta Abutment Components

Fixture Transfer Impression Coping

- Components for fixture level impression taking
- For closed tray impressions
- Triangular arc enabling precise placement
- Use a 1.2 hex driver (torque manually)
- Packing unit
 - Octa : impression coping body + guide pin
 - Non-octa : impression coping

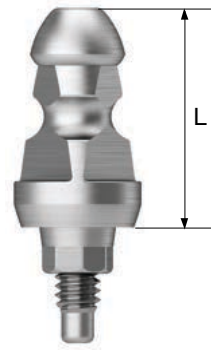

- R** Regular (Green)
- W** Wide (Blue)

P \ L	9.5		12.5		9.5		12.5	
	Octa				Non-Octa			
Type								
Ø 4.8					SSCTIS480	SSCTIL480N	SSCTIS480N	SSCTIL480N
Ø 6.0					SSCTIS600N	SSCTIL600N	SSCTIS600N	SSCTIL600N



046

SS SYSTEM

047

SS SYSTEM

Fixture Lab Analog

- A lab analog for fixture level impression
- Select an appropriate fixture platform; Ø 4.8/6.0

- R** Regular (Silver)
- W** Wide (Blue)

D	
Ø 4.8	SSFA480
Ø 6.0	SSFA600

PROSTHETIC FLOW DIAGRAM 3

Octa

Abutment Level Impression

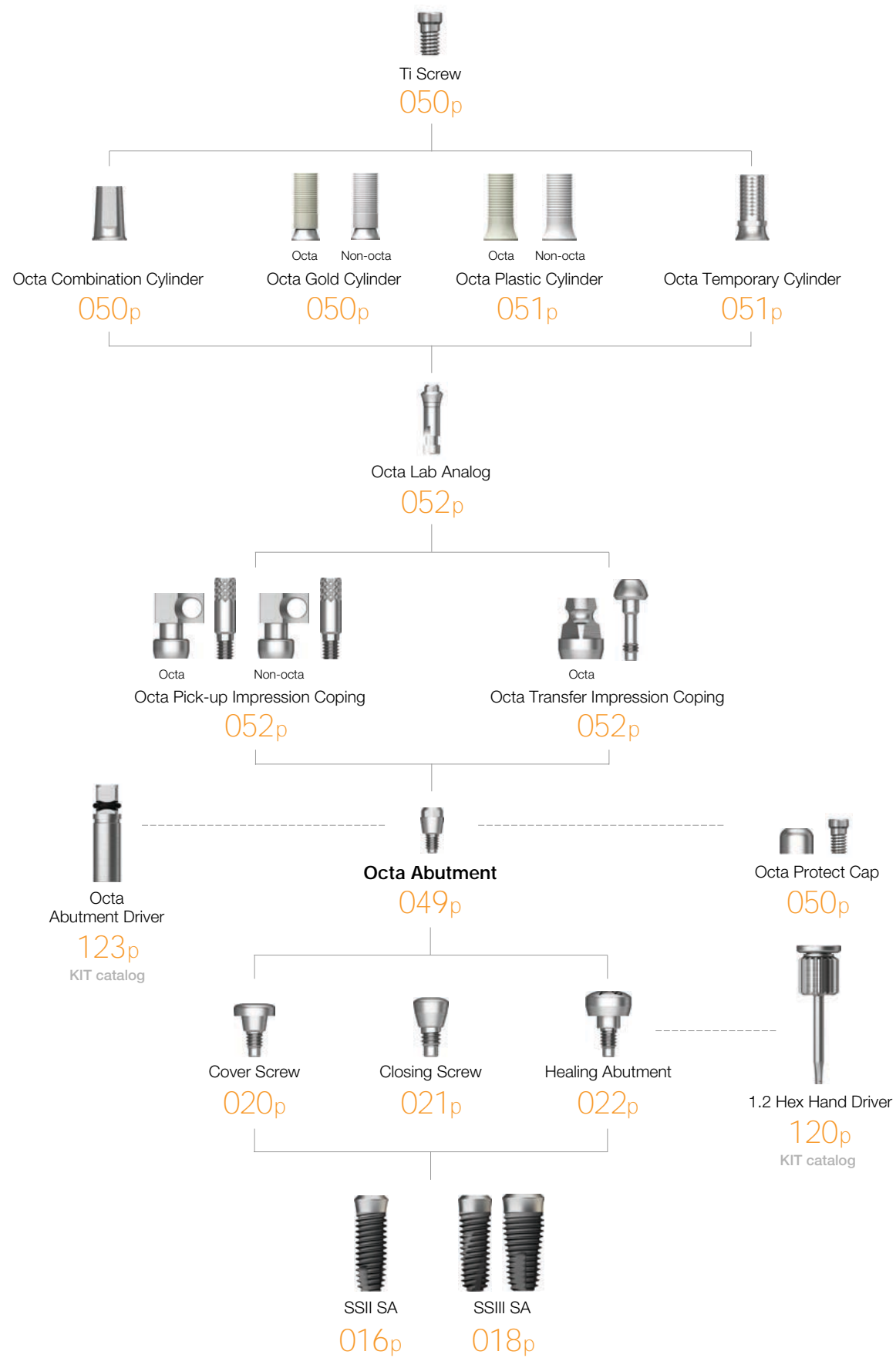

Octa Abutment



- Screw-retained prosthesis for multiple prosthetic options
- Angle compensation of up to 60°
- Use a dedicated outer driver (code : ODSL/ODSS)
- Recommended tightening torque : 30Ncm



D Ø4.8



SSOA480

D Ø6.0



SSOA600

048

SS SYSTEM

049

SS SYSTEM

Octa Abutment Components

Octa Protect Cap

- Protective cap
- Use a 1.2 hex driver (fastened manually)
- Packing unit : protect cap + Ti screw

Protect cap + Ti screw order code
: product code + TH (ex : SSHC480TH)

- R** Regular
- W** Wide

D



Ø 4.8
Ø 6.0
 Ti screw
 : SSFS (Ø 4.8 / Ø 6.0)

SSHC480
SSHC600

Octa Gold Cylinder

- Screw-retained prosthesis
- Customized prosthesis cast with gold alloy
- Cylinder melting point : 1400~1450°C
- Fastened using a 1.2 hex driver
- Recommended tightening torque : 20Ncm
- Packing unit : cylinder + Ti cylinder screw

Cylinder + Ti screw order code
: product code + TH (ex : SSGCO480TH)

- R** Regular
- W** Wide

D \ Type Octa Non-Octa



Ø 4.8
Ø 6.0
 Ti screw
 : SSFS (Ø 4.8 / Ø 6.0)

SSGCO480 SSGCN480
SSGCO600 SSGCN600

Octa Temporary Cylinder

- Provisional prosthesis (Ti Gr-3)
- Fastened using a 1.2 hex driver
- Recommended tightening torque : 20Ncm
- Packing unit : cylinder + Ti cylinder screw

Cylinder + Ti screw order code
: product code + TH (ex : SSTCO480TH)

- R** Regular
- W** Wide

D \ G/H 0 2

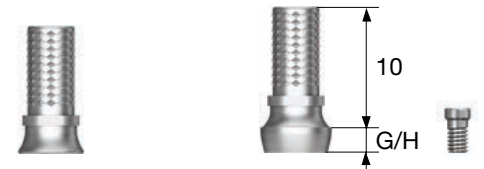

Ø 4.8
Ø 6.0
 Ti screw
 : SSFS (Ø 4.8 / Ø 6.0)

SSTCO480 SSTCO482
SSTCO600 SSTCO602

Octa Plastic Cylinder

- Screw-retained prosthesis
- Customized prosthesis cast with non-precious alloys
- Use a 1.2 hex driver
- Recommended tightening torque : 20Ncm
- Packing unit : cylinder + Ti cylinder screw

Cylinder + Ti screw order code
: product code + TH (ex : SSPSO480TH)

- R** Regular
- W** Wide

D \ Type Octa Non-Octa



Ø 4.8
Ø 6.0
 Ti screw
 : SSFS (Ø 4.8 / Ø 6.0)

SSPSO480 SSPSN480
SSPSO600 SSPSN600

Octa Combination Cylinder

- Combination-retained prosthesis
- Compatible with bone octa/non-octa specs
- Use a 1.2 hex driver
- Recommended tightening torque : 20Ncm
- Packing unit : cylinder + Ti cylinder screw

Cylinder + Ti screw order code
: product code + TH (ex : SSOCC480TH)

- R** Regular
- W** Wide

D

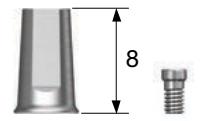

Ø 4.8
Ø 6.0
 Ti screw
 : SSFS (Ø 4.8 / Ø 6.0)

SSOCC480
SSOCC600

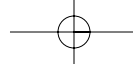

Octa Abutment Components

Octa Pick-up Impression Coping

- A pick up impression coping for octa abutment
- Use a 1.2 hex driver (fastened manually)
- Packing unit : impression coping body + guide pin(*)

R Regular (Silver)

W Wide (Blue)

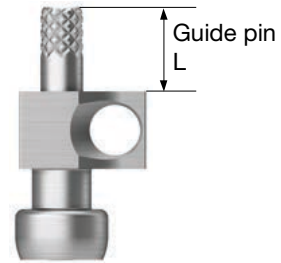

D \ L	Octa		Non-Octa		Guide Pin	
					10	15
	Ø 4.8 Ø 6.0	SSICO480 SSICO600	SSICN480N SSICN600N		SSGS100	SSGS150*



Octa Transfer Impression Coping

- A pick-up impression coping
- Use a 1.2 hex driver (fastened manually)
- Packing unit : Impression coping body + guide pin

R Regular (Silver)

W Wide (Blue)

D	
	Ø 4.8 Ø 6.0
	SSOTI480 SSOTI600

Octa Lab Analog

- A lab analog
- Use a 1.2 hex driver (fastened manually)

R Regular (Silver)

W Wide (Blue)

D	
	Ø 4.8 Ø 6.0
	SSLA480 SSLA600

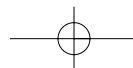

PROSTHETIC FLOW DIAGRAM 4
O-ring / Locator®
 Overdenture



O-ring Abutment

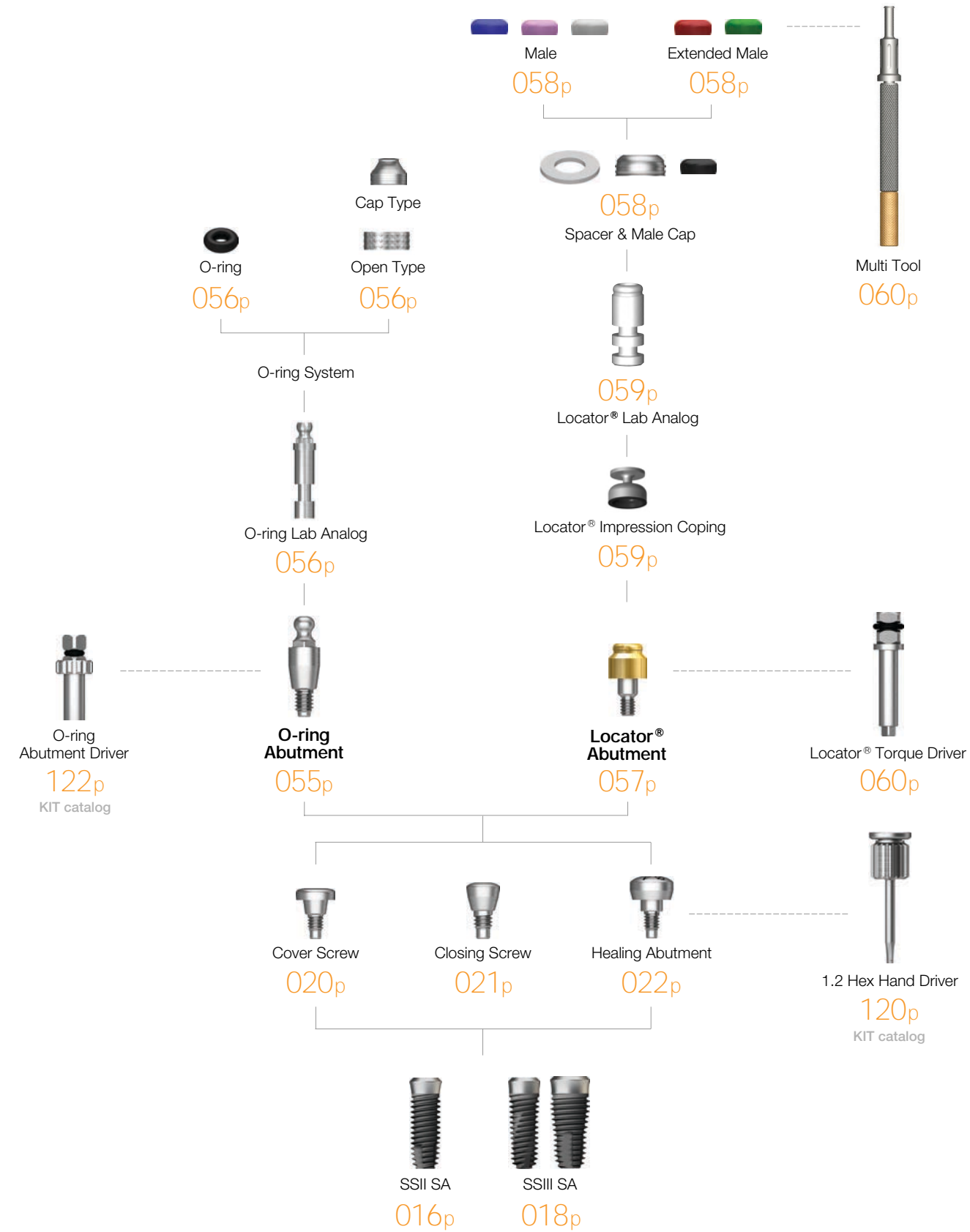

- Retains overdenture with o-ring system
- Angle compensation of up to 20°
- Torque using an outer driver (code : AORD)
- Recommended tightening torque : 30Ncm

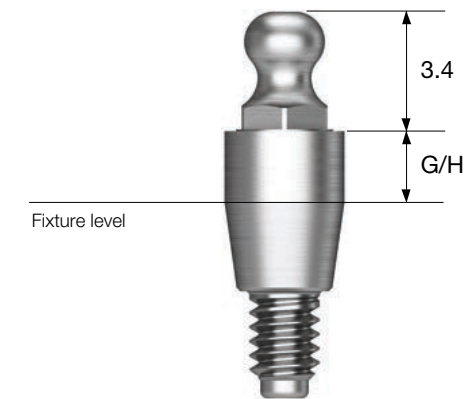

D Ø4.8
R



054

SS SYSTEM

055

SS SYSTEM

O-ring Abutment Components

O-ring Retainer Cap Set

- O-ring housing
- Place an appropriate o-ring in the metal housing before connecting to the abutment
- Packing unit : retainer cap + o-ring



RCS01

O-ring Retainer Set

- Used when vertical dimension is shorter than the retainer cap
- Packing unit : retainer cap + o-ring



RS01

O-ring Set

- O-ring set
- Packing unit : o-ring x 5ea



OAON01S

O-ring Lab Analog

- A lab analog for o-ring abutment



OAL

Locator[®] Abutment

- Genuine zest anchors abutment
- Angle compensation of up to 40°
- 1.5mm lower profile, attachment with various and stable retention forces
- Torque using a dedicated outer driver (code : TWLDLK/TWLDLSK)
- Recommended tightening torque : 30Ncm

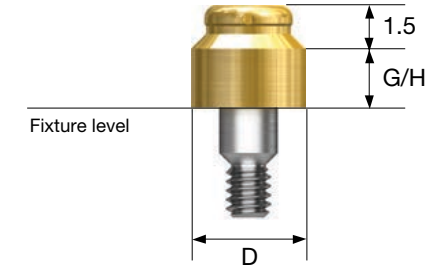

D Ø4.8

R



Locator® Abutment Components

Locator® Male Processing Kit

- Components
 - Block out spacer / denture cap connected black processing male
 - Replacement male blue/pink/clear
- A full range of retentive males are included with each denture cap to allow personalized retention for each specific patient
- Locator core tool places and removes nylon retentive males
- Packing unit : 2set



LMPS

Locator® Replacement Male

- Retention force : approx. 6N
 - Angle compensation up to 20°
 - Packing unit : 4ea
-
- Retention force : approx. 12N
 - Angle compensation up to 20°
 - Packing unit : 4ea
-
- Retention force : approx. 22N
 - Angle compensation up to 20°
 - Packing unit : 4ea



LRM06S



LRM12S



LRM22S

Locator® Extended Replacement Male

- Retention force : approx. 6N
 - Angle compensation up to 20~40°
 - Packing unit : 4ea
-
- Retention force : approx. 12N
 - Angle compensation up to 20~40°
 - Packing unit : 4ea



LEM06S



LEM12S

Locator® Black Processing Male

- A nylon male used in prosthesis fabrication process
- Packing unit : 4ea



LBPS

Locator® Block Out Spacers

- Place block-out spacers on the heads of the locator abutments. Position denture cap with integrated black processing onto the locator abutments. If necessary, add additional block-out spacers until no gap is visible between female, block-out spacer and gum.
- Packing unit : 20ea



LBSS

Locator® Impression Coping

- A pick up impression coping
- Closed tray
- Packing unit : 4ea



LICS

Locator® Lab Analog

- A lab analog for locator abutment
- Packing unit : 4ea



LAL50S

Locator® Abutment Components

Locator® Core Tool

- Places and removes nylon retentive males in the denture cap
- Separated into three different tools, includes a hand driver for locator abutment



LCCT

Locator® Torque Driver

- A torque driver for locator abutment

Type Short Long



TWLDSK



TWLDLK

OSSTEM[®]
IMPLANT

Instructions for Use (AUG. 2017, Ver. 5.5)

Description of Osstem implant system

Osstem Implant is a brand for implant materials for dental practices, and the fixture is made mainly of titanium. The abutment, prosthetic components and tools for the Osstem Implant system are compatible with the Osstem Implant fixture only. Using this product in combination with products from other manufacturers may cause various problems including loosening and fracture due to incomplete locking and compatibility issues. Refer to the manual or the catalogue or our website (www.osstem.com) for details. See the product label for the product code, specifications, manufacturing date, and expiration date.

Sterility

The fixture, cover screw, and healing abutment are cleansed and sterilized with gamma radiation. This product is a disposable sterilized medical device intended for one-time use. In order to prevent contamination or infection of the product or operated site, the product must be used using a sterilized instrument in a sterilized environment. Damaged products, products with open packaging, or expired products must be discarded due to potential risks of contamination, infection, or osseointegration failure. Re-sterilization or re-use of the product may result in infection, osseointegration failure, or implant damage due to reduced accuracy.

Storage condition

Keep the product in a dry place at room temperature(1~30°C). Keep away from direct sunlight.

General precautions

The surgical technology of dental implant involves an expert, complex procedure. Formal training is required to perform implant surgery. Careful considerations must be made before the operation in case of bone disorders (osteoporosis, osteomalacia) or metabolic disorders of the bone.

Precautions

Determine the local anatomy and suitability of the available bone for implant placement. Prepare the implant considering the expected situations and cautions. Excessive occlusal load may cause loosening or fracture of an implant. In order to avoid this condition, the implant must be placed in accurate location and direction considering the relationship between the implant and opposing dentition. Visual inspection as well as panoramic and periapical radiographs are essential to determine anatomical landmarks, occlusal conditions, periodontal status, and the adequacy of the bone. Adequate radiographs, direct palpation, and visual inspection of the implant site are necessary prior to implant surgery.

Procedural precautions

Osstem Implant System is for single and two stage surgical procedures. As much as possible, try to minimize damage to the cell tissue and surgical trauma, pay special attention to maintaining the temperature at the implant site and removal of the source of contamination and infection. All drills and taps must be sufficiently and continuously irrigated for cooling during use. Implant placement should be accomplished at very low speed (25-30 rpm) or manually. Excessive torque (greater than 55Ncm) in the fixture placement can have adverse effects such as partial fracture or necrosis of the bone. Placing an implant tilted by 30° or higher is not recommended due to possible fracture of implant. Immediate loading to the fixture right after the surgery should be avoided. The bone quality and initial stability after fixture placement are important elements in determining the appropriate loading time. Mini-diameter implant or implant with diameter of 4.0 or less and which integrates with angled abutment may be fractured due to limitations of structural rigidity. They are not recommended for use in a posterior area. The Ultra-Wide fixtures are intended to be used only to replace molar teeth and

that angled abutments are not to be used with the Ultra-Wide fixtures. Evaluate the quantity of bone and radiographs to assess any potential anatomical contraindications to use of the Ultra-Wide fixture. For the placement of the Short Implant (diameter is 5mm or more and length is shorter than 7mm) which is used on the molar region only, clinicians should closely examine the patients for any of the following conditions: 1) perimplant bone loss, 2) changes to implant's response to percussion, 3) radiographic changes in bone to implant contact along the implant's length. If a short implant shows mobility or greater than 50% bone loss, the implant should be considered for possible removal. And clinicians should consider a two-stage surgical approach, splinting a short implant to an additional implant, and placement of the widest possible fixture. Allow longer healing periods for osseointegration before fabrication of the prosthesis and avoid immediate loading. Products with diameter of 3.25mm or less must be used exclusively for mandibular anterior teeth in order to prevent fracture due to excessive occlusal load. It is recommended that you should avoid applying HA coated fixture to hard bone, and the insertion torque of the implant should be less than 35Ncm, because cracks or damages might occur in the coated layer during implant placement. The surfaces of CA and SOI have the same physical shape as the SA surface made through blasting and etching treatments. After the SA surface treatment, to prevent the products' exposure to the atmosphere, CA is stored in solution, whereas SOI is stored in water-film coating form; it is designed to maintain the chemically activated state of the SA surface. Thus, CA or SOI products should be implanted in the target region at least within 15 minutes of taking them out of the container.

Warning

The selection of inappropriate patients and surgical methods can cause implant failure or loss of bone supporting the implant. Osstem implants must not be used for purposes other than the recommended use and must not be remodeled. Implant mobility, bone loss, and chronic infection can result in failure of the implant surgery.

Indications for use

The Osstem Implant System is an artificial dental root that has been designed for use in dental implant treatment in order to recover lost teeth. The system is implanted via a surgical method in maxillary or mandibular bone to replace natural dental root. The Osstem Implant System is indicated for use in partially or fully edentulous mandibles and maxillae, in support of single or multiple-units restorations including; cemented retained, screw retained, or overdenture restorations, and final or temporary abutment support for fixed bridgework. It is intended for delayed loading. Products with diameter of 3.25mm or less must be used exclusively for mandibular anterior teeth in order to prevent fracture due to excessive occlusal load.

Side effects

A few problems may occur after the operation (loss of implant stability, damage of prosthesis, etc.). Deficient quality and quantity of the remaining bone, infection, allergic reaction, inferior oral hygiene or uncooperativeness of patient, implant mobility, partial deterioration of tissue, and improper position or arrangement of implants may cause the above mentioned problems.

Contraindications

- Contraindications include the following, but are not limited to:
- Patients with hemophilia or difficulties related to bone or wound treatment
 - Patients with uncontrollable diabetes, heavy smoker or alcoholic
 - Patients whose immunity system is inactive due to chemical therapy or radiation therapy
 - Patients with oral infection or inflammation (improper oral hygiene, bruxism)
 - Patients with untreatable occlusion/joint disorder, insufficient dental arch space
 - Any patient who is not suitable for an surgery

062

USER MANUAL

OSSTEM[®]
IMPLANT

Manufacturer : Osstem Implant Co., Ltd.
203, Geoje-daero, Yeonje-gu, Busan, Korea
TEL 82-51-850-2500 FAX 82-51-861-4693

EC REP

DEUTSCHE OSSTEM GmbH.
Mergenthalerallee 35-37
65760 Eschborn, Germany
+49-(0)6196-777-5500

Storage condition

Dry place at room temperature

Rx only

For USA only : Federal law restricts this device to sale by or on the order of a dentist



2460



Sterilized using irradiation



Use by



Manufacture



Do not reuse



Date of manufacture



Keep away from sunlight



Catalogue number



Non-Sterile



Keep dry



Batch code



Do not re-sterilize



Caution, Consult accompanying documents

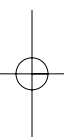
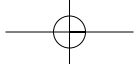

OSSTEM[®]
IMPLANT

